



---

## DEMISTER PADS/ MIST ELIMINATORS

**HAYER STANDARD**

INDIA PRIVATE LIMITED  
(In joint venture with Haver & Boecker, Germany)

# CONTENTS

02	ABOUT US
03	MESH PAD MIST ELIMINATORS
05	DESIGN AND ENGINEERING DATA
05	HAST WIRE MESH MIST ELIMINATORS
06	TYPICAL PROCESS APPLICATION FOR MIST ELIMINATORS
08	SIZING
09	SPECIALIST SOLUTIONS TO MIST ELIMINATORS PROBLEMS
11	MATERIAL OF CONSTRUCTION
12	METAL MESH PADS
13	OTHER MESH PADS

## ABOUT US

Haver Standard India Pvt Ltd (HAST) is the largest manufacturer of wire mesh and demister pads in India, and the only company manufacturing sieves in India which are compliant to DIN, ISO and ASTM standards. We are also a renowned producer of silver granular and wire mesh catalysts for over 50 years and cater to more than 60% of Formaldehyde plants in India.

We have been in the wire weaving business since 1958, and since 1988 we have an active joint venture with Haver & Boecker, Germany who are in this business since 1887. We are ISO 9001-2008 compliant since 1996.

Based on our combined expertise of more than 100 years of experience in wire fabric technology, we provide innovative systems for particle analysis and the most suitable woven wire cloth for every demand. Meticulous handling of production processes, with special attention to quality control measures, is the hallmark of our company. Emphasis on quality is instilled into every process right from the bottom to the top. This combined with our mindset of continuous learning and

improvement, ensures that we deliver high quality products and service at competitive prices.

Our products are used in a wide range of industries which include oil refinery, agriculture, desalination, OEM, chemical, polymer, pharmaceutical and minerals. Our products are also approved by leading inspection agencies and engineering contractors including EIL, TUV, DNV and BVIS. The company has an established market in India as well as Europe, and Middle & Far East Asia.

At HAST we have a fully equipped state-of-the-art manufacturing facility at Halol, the outskirts of Baroda, Gujarat. The total area of the manufacturing plant is in excess of 100,000 sq.ft. with further land area for expansion, and has the largest installed capacity for woven wire cloth in the country. All our products are now manufactured under one roof in accordance to ISO standards.

Our aim is to make you, our Customer, happy by satisfying all your filtration needs.





## MESH PAD MIST ELIMINATORS

### WHAT IS A HAST MIST ELIMINATORS?

The HAST eliminators is a fabricated Pad formed from symmetrical interlocking Loops of knitted metal wire or plastics filaments. This pad with the high free volumes and large impingement area can be installed in any new process vessel to provide separation efficiencies up to 99% for particles down to five microns, with pressure drop with vicinity of 25 mm WC. The HAST mist eliminators is a static, in-line device and in majority of cases it can be installed in evaporators, scrubbers, pressure vessels etc. , without a special housing . There is a practically no maintenance required except for cleaning when used in fouling services.

Most HAST mist eliminators are supplied with complete rigid support grids, which allows direct installation on to appropriate support such as beams and rings within the vessel. Sectional installation allows ease of handling and access through vessel man ways.

### MIST ELIMINATORS

The separation of liquid droplets entrained in a vapor (gas) stream is a key requirement in many process operations to improve the (capacity & separation) performance of the plant, to protect downstream equipment, to reduce the loss of valuable chemicals to comply with stringent environmental protection regulation.

At HAST we have a full of range of mist eliminators (demisters) to ensure tailor made solutions for your applications.

Mesh type demisters are designed to achieve an optimum gas velocity to maximum removal efficiency. To high velocity will result in re-entrainment of the liquid droplets whilst too low velocity will allow very small droplets to pass straight through the demister.

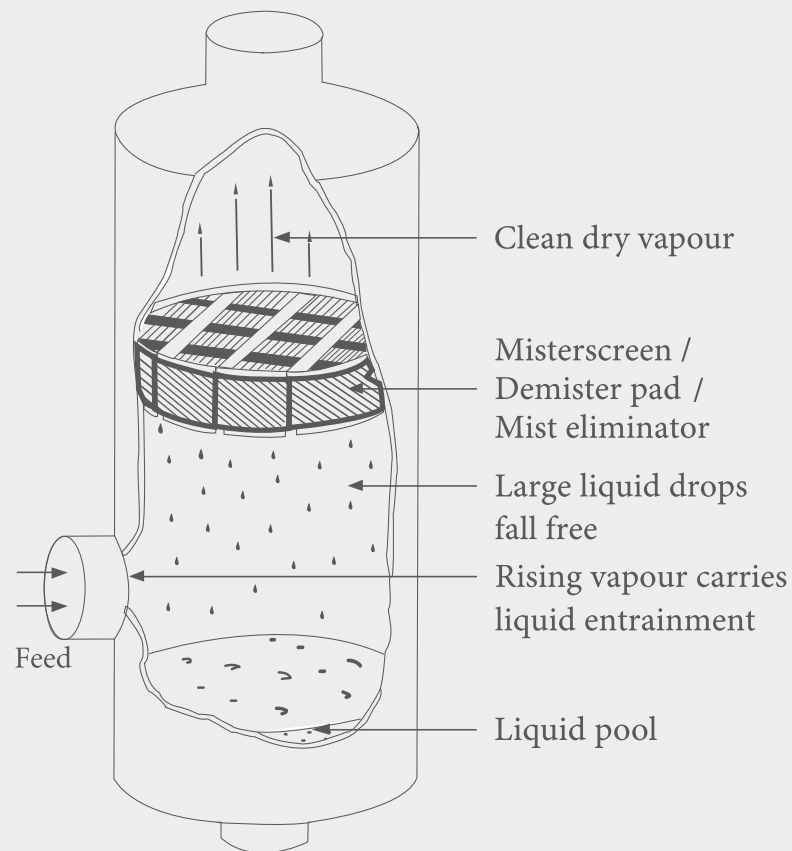

Fig 1: Separation of droplets

## WORKING OF MIST ELIMINATORS.

Mesh pad mist eliminators remove liquid droplets by impingement of the droplets on the wire surface. The droplets agglomerate and increase in size until they are sufficiently large enough to drain from pad by gravity.

Mesh demister efficiency is preliminary a function of droplets size, wire size, specific surface area of the mesh, pad thickness and physical properties of the system. For a standard specification mesh demister ( wire  $\varnothing$  0.28 mm, density 145 kg/m<sup>3</sup>, surface area 300 m<sup>2</sup>/m<sup>3</sup> ) removal efficiency is typically 100 % for a droplets 5  $\mu$ m and greater in diameter . Higher surface area mesh demister 500 m<sup>2</sup>/m<sup>3</sup> using a reduce wire diameter 0.15mm can be used to improve the removal efficiency.

Mesh demister can be installing either horizontally or vertically. With horizontal gas flow through the demister the capacity is 30 5 greater than compared to vertical flow, thus the demister can be smaller.

Mesh pads are typically 150mm thick with 25mm thick grids on either side making on overall thickness of 200mm. Many years of experience have shown that a 150 mm pad thickness provide optimum performance in hydrocarbon process with a vertical gas flow configuration.

## DESIGN AND ENGINEERING DATA

The separating action of separator largely depends upon the contact surface area necessary for impingement, which must be very distributed. Generally speaking, a higher free volume leads to lower pressure drop. In

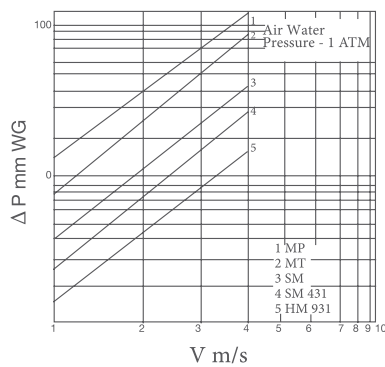

Fig 2: Pressure Drop vs Gas Velocity

critical cases, it may be necessary to decide whether pressure drop or efficiency should be sacrificed. However the HAST mist eliminators allows the greatest possible efficiency at the lowest possible pressure drop.

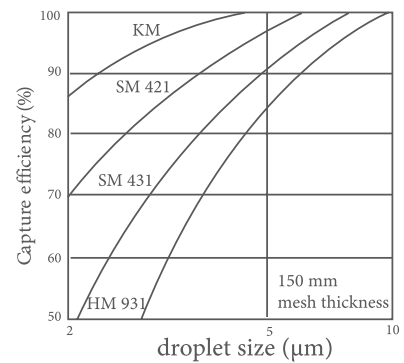

Fig 3: Capture efficiency vs droplet size for four types of Misterscreen / Mist eliminators

## HAST WIRE MESH MIST ELIMINATORS

HAST wire mesh mist eliminators have excellent track records as a low cost, highly versatile and efficient method of removing liquid entrainment from gas streams. They are produced as bed of knitted mesh which presence a tortuous path and large surface area achieved by impingement on, and captured by the filaments of the mesh where the droplets coalesce and drain.

Installation can be variety of ways but gas flow is usually either vertically upwards, with liquid draining counter- current gas flow, or

horizontal, with the liquid draining in a direction normal to the gas flow.

Each mist eliminators are manufactured to suits the dimensions of the vessels or housing into which it will be installed.

Accessories such as tie wire, bolting and clamps can be supplied where necessary.



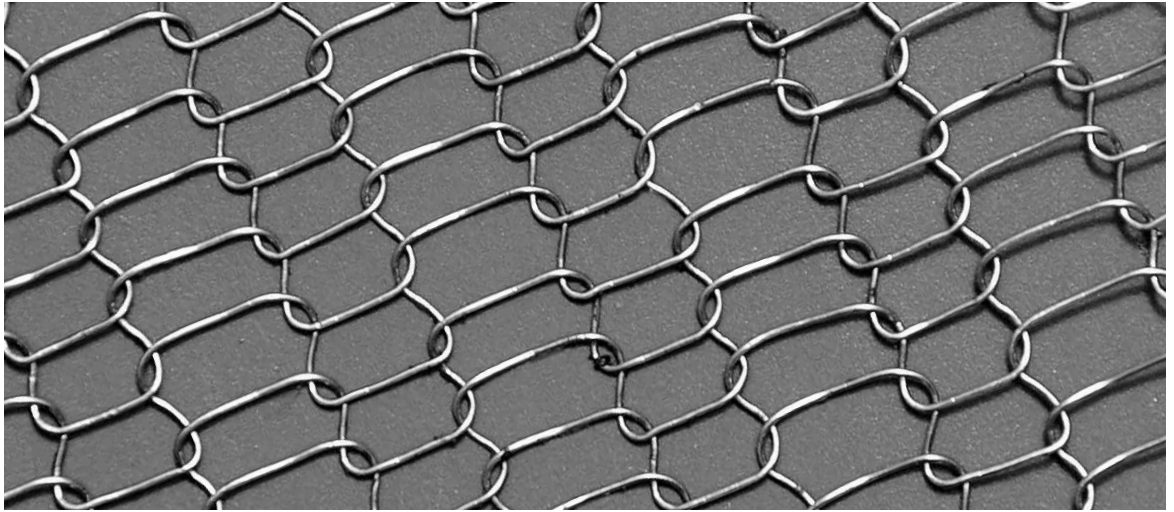

## TYPICAL PROCESS APPLICATION FOR MIST ELIMINATORS

In many process operations, gases and liquid contact each other to form a mist and if the gas is travelling too fast to allow the liquid droplets to settle out under gravity, they become suspended ( or entrained ) in the gas or vapor . In most cases, the entrainment must be removed to purify the gas and prevent potential process or environmental contamination.

Installation of knit mesh mist eliminators is an effective solution to liquid entrainment problem in many process applications throughout industry.

### OIL AND GAS PRODUCTION

- Three Phase Separators
- Inlet Scrubbers
- Compressor System
- Cold Separators
- Glycol Dehydration
- Amine Absorption Column

### POWER GENERATION

- Steam Drums
- Seawater Desalination Plant
- Flue Gas Desulphurisation
- Compressor System



## CHEMICAL INDUSTRY

- Distillation
- Gas Absorption and Stripping
- Condensation
- Gas Compression
- Dehumidification and Drying
- Spray Removal and Desalination

## PETROLEUM REFINERIES

- Crude Oil Distillation
- Catalytic Cracking
- Alkylation
- Stripping Operation in Desulphurization and Hydro Fining Process
- Compression Operations in Natural Gas Processing
- Sulphur Condensers



## SIZING

For equipment based on direct and/or inertial interception, gas stream velocity affects all three principles involved in separation (impingement, coalescence and drainage). Flooding or re-entertainment of liquid can occur if the flow of gas prevents drainage, and the effective area of the mist eliminators is therefore established by determining an appropriate superficial velocity for the equipment. The overall performance of the mist eliminators is then a balance between efficiency and pressure drop.

$V$  = Maximum superficial gas velocity (m/s)

$\rho_l$  = liquid density (kg/m<sup>3</sup>)

$\rho_v$  = Gas density (kg/m<sup>3</sup>)

$K$  = a constant which is specific to the separation equipment and is a functional of process parameters such as:

- Liquid Loading
- Gas and Liquid Viscosity
- Gas Pressure
- Surface Tension

Above factors are often applied to allow a safety margin for exceptional conditions such as liquid slugs and gas surges. For example, mesh mist eliminators should generally be designed with velocity of 75 % of  $V$ , to allow for surges and with a minimum velocity of 30 % of  $V$ .

# SPECIALIST SOLUTIONS TO MIST ELIMINATORS PROBLEMS

## MIST ELIMINATOR DESIGN

- Problem definition
- Sizing and specification of appropriate knit mesh mist eliminator.
- Analysis of inlet configuration and vessel layout.
- Detailed designed of internal and supports
- Designed available for installation in either vertical or horizontal orientation.
- Performance warranty.



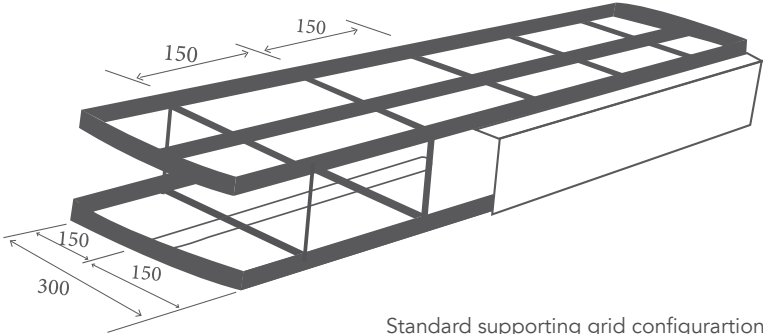

Standard supporting grid configuration

### MANUFACTURER

- HAST mist eliminators tailor made to suit specific vessel dimensions and configuration
- Construction and wide variety of material to suit even the most corrosive process environments
- Mesh mist eliminators supplied as pads only, or complete with top and bottom supporting grids ready for direct installation on vessel.
- Sectional construction for ease of handling and access through man ways
- Complete package of equipment including vessel and internal can be provide where necessary

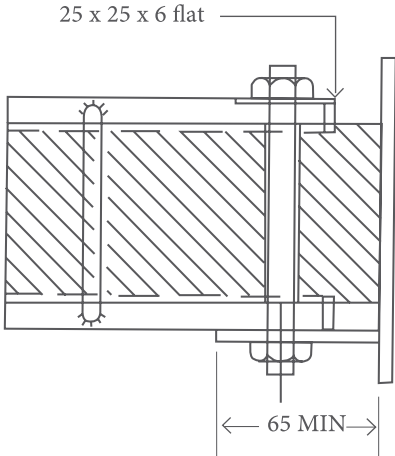

Removable from top

### DELIVERY

- HAST can arrange delivery to your premises wherever you are in the world

### SITE SUPERVISION

- For complex projects, our technical team can provide site supervision of installation

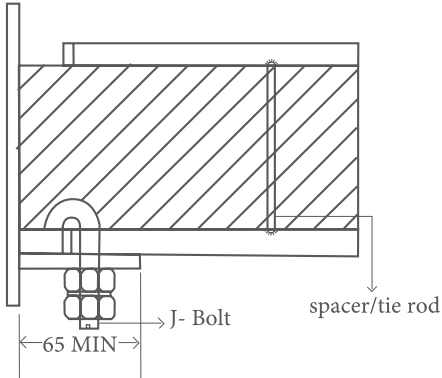

Removable from bottom

# MATERIAL OF CONSTRUCTION

## MATERIALS

## LIQUID PRODUCT SEPRATED

Nickel

caustic soda, food product

Monel

caustic soda & other alkalis, dilute acid

304 Stainless  
petroleum

water solution, nitric acid, reduced crude  
fractions, etc

316 Stainless  
naphthenic

fatty acids, reduced crude containing  
acid & other corrosive

430 Stainless

nitric acid, water steam

Copper

freons, alcohol

Synthetic Fiber/ Plastics

for corrosive service at moderate temperature

## METAL MESH PADS

Values for stainless steel, a variety of other metals are available.

Free Volume	Density (KG/ M <sup>3</sup> )	Surface Area (M <sup>2</sup> /M <sup>3</sup> )	Application
97%	240	450	Very High Efficiency, Very Clean Service
97.5%	192	350-400	Heavy Duty
97.80%	175	320-350	For General Use
98%	145	270-300	Standard General Purpose Media
98.60%	110	200	High Velocity , Dirty Service
99 %	80	145-150	Minimum Pressure Drop, Dirty Service

## OTHER MESH PADS

Material	Free Volume	Density (Kg/M <sup>3</sup> )	Surface Area (M <sup>2</sup> /M <sup>3</sup> )	Application
Polypropylene	95%	100	1750-1777	High Performance-Acid Mists
	98%	70	1225-1245	Acid Mists & Marine Engine
	95%	50	875-888	Intake With Minimum Pressure Drop
PVDF	96%	80	530	Highly Corrosive Condition
PVC	93%	100	950	Highly Corrosive Condition



Registered & Marketing Office Address:

Haver Standard India Pvt. Ltd.  
G4, Turf Estate, Dr. E. Moses Road,  
Shakti Mills Lane, Mumbai 400 011. India.

Tel. : 022 66661112 / 3

Email: wiremesh@haverstandard.com

Factory Address:

Haver Standard India Pvt. Ltd.  
Khandiwada, Baroda-Halol Road,  
Post Asoj, District - Vadodara 391 510.

Tel. : +91 8758 221115 / 6

Email: wiremesh@haverstandard.com